



Dial Test Indicators

501 / 502 / 511 / 512 Series



Vertical



Horizontal

FEATURES

- Graduation: Inch .0001"; .0005", Metric 0.002mm; 0.01mm
- Jeweled bearings
- Inch unit comes with $\text{\O}3/8"$ dovetail stems; Metric unit comes with $\text{\O}8\text{mm}$ dovetail stems
- Easy to read yellow face
- Horizontal models and Vertical models are available
- Ruby contact point
- 501-02-1 is with copper body

STANDARD ACCESSORIES

- Warranty card, Instruction manual, Calibration certificate

Full Set



Base Set

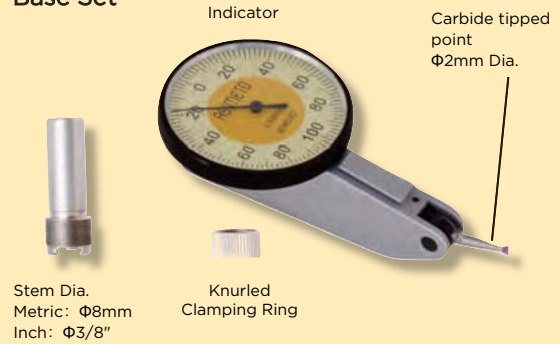

SPECIFICATIONS

						D: $\text{\O}32\text{mm}$ / $\text{\O}1.26"$ Dia.	D: $\text{\O}40\text{mm}$ / $\text{\O}1.57"$ Dia.			
Range	Resolution	Dial Reading	Accuracy	L	Note	Code No.	Set Code No.	Code No.	Set Code No.	
Inch										
.008"	.0001"	0-4-0	$\pm .0001"$	12.8mm	Horizontal	501-78-3	501-78-7	-	-	
.03"	.0005"	0-15-0	$\pm .0005"$	13.5mm	Horizontal	501-73-3	501-73-8	-	-	
.008"	.0001"	0-4-0	$\pm .0001"$	12.8mm	Vertical	501-78-5	-	-	-	
.03"	.0005"	0-15-0	$\pm .0005"$	13.5mm	Vertical	501-73-5	-	-	-	
.03"	.0005"	0-15-0	$\pm .0005"$	24mm	Horizontal	501-73-6	-	-	-	
Metric										
0.2mm	0.002mm	0-100-0	0.004mm	12.2mm	Horizontal	501-02-1	-	-	-	
0.2mm	0.002mm	0-100-0	0.004mm	12.8mm	Horizontal	501-02-2	501-02-7	502-02-2	502-02-7	
0.5mm	0.01mm	0-25-0	0.013mm	14.4mm	Horizontal	501-05-2	501-05-7	502-05-2	502-05-7	
0.8mm	0.01mm	0-40-0	0.013mm	14.4mm	Horizontal	501-08-2	501-08-7	502-08-2	502-08-7	
0.8mm	0.01mm	0-40-0	0.013mm	25.4mm	Horizontal	501-08-8	-	-	-	
1.0mm	0.01mm	0-50-0	0.013mm	18.8mm	Horizontal	501-10-2	501-10-7	502-10-2	502-10-7	
1.0mm	0.01mm	0-50-0	0.013mm	32.6mm	Horizontal	501-10-8	-	-	-	
0.2mm	0.002mm	0-100-0	0.004mm	12.8mm	Vertical	501-02-4	-	502-02-4	-	
0.5mm	0.01mm	0-25-0	0.013mm	14.4mm	Vertical	501-05-4	-	502-05-4	-	
0.8mm	0.01mm	0-40-0	0.013mm	14.4mm	Vertical	501-08-4	-	502-08-4	-	
1.0mm	0.01mm	0-50-0	0.013mm	18.8mm	Vertical	501-10-4	-	502-10-4	-	
G Series										
0.2mm	0.002mm	0-100-0	0.004mm	11.8mm	Horizontal	501-02-6	-	502-02-6	-	
0.8mm	0.01mm	0-40-0	0.008mm	11.8mm	Horizontal	501-08-6	-	502-08-6	-	
IP53 model										
0.2mm	0.002mm	0-100-0	0.004mm	11.8mm	Horizontal	511-02-6	-	512-02-6	-	
0.8mm	0.01mm	0-40-0	0.013mm	11.8mm	Horizontal	511-08-6	-	512-08-6	-	



Dial Test Indicators

501 / 502 / 511 / 512 Series

Dimension

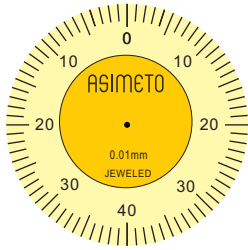
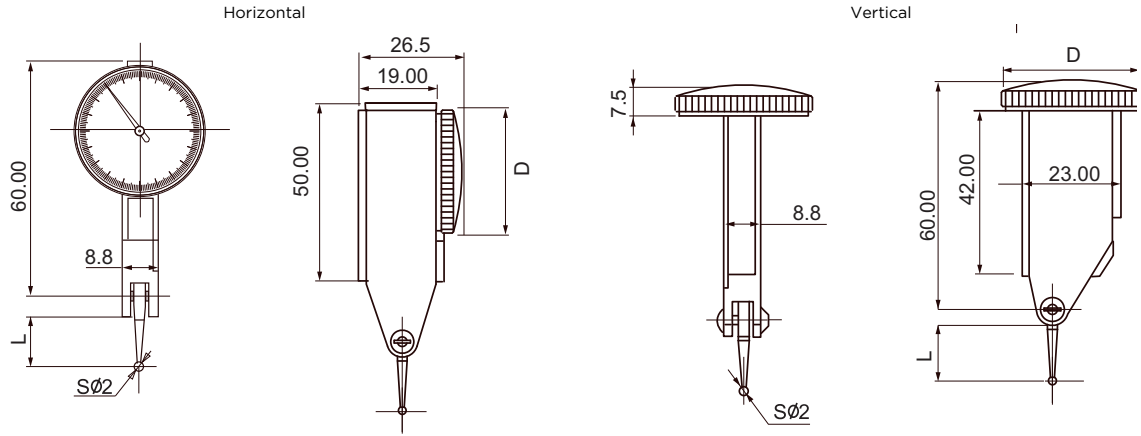

501-08-2 502-08-2
 501-08-4 502-08-4
 501-08-7 502-08-7
 501-08-6 502-08-6
 511-08-6 512-08-6

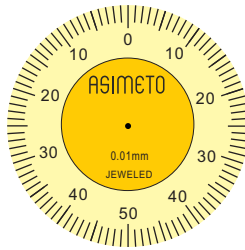

501-10-2 502-10-2
 501-10-4 502-10-4
 501-10-7 502-10-7

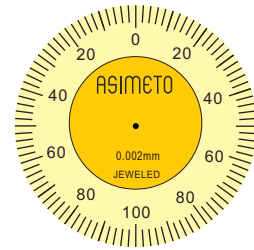

501-02-2 502-02-2
 501-02-4 502-02-4
 501-02-7 502-02-7
 501-02-6 502-02-6
 511-02-6 512-02-6

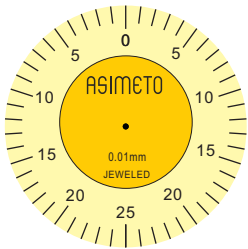

501-05-2 502-05-2
 501-05-4 502-05-4
 501-05-7 502-05-7

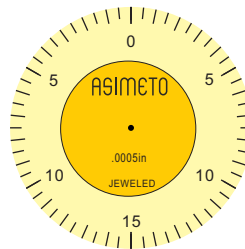

501-73-3 501-73-8
 501-73-5 501-73-6

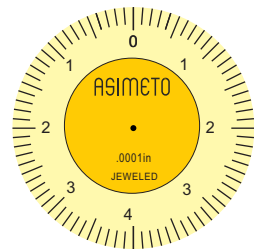

501-78-3
 501-78-5
 501-78-7